

简介

NU系列针形阀设计应用于较为苛刻的工作环境，额定工作压力6000 psig (414 barg)，工作温度可高达648℃。采用非旋转式铆接阀芯和组合阀盖结构，可靠性高，具有较长的使用寿命。

Introduction

NU series needle valves are designed for severe service applications up to 6000 psig (414 bar) and temperatures as high as 648 °C. We adopt the non-rotating riveting stem tip and union bonnet structure which brings high reliable performance and long service life.



特点

- 采用活动阀芯与阀杆铆接，在阀门关闭的瞬间，阀芯只上下移动但不转动，避免了密封面刮伤
- 填料螺栓的设计使阀门在关闭或开启位置都能进行填料调节
- 阀杆螺纹位于填料上方，避免介质的冲洗与侵蚀

Feature

- We adopt riveting procedure of the active stem tip and valve rod. All the action in the fitting moves axially instead of in a rotary motion during the closure moment of the valve to reduce the seat galling.
- The packing can be adjusted when the valve in on or off state due to the design of the packing bolts.
- Threads above packing can avoid the corrosion from medium.

- 组合阀盖结构设计，确保在苛刻的工作环境下密封可靠
- 全开位置时具有上密封结构
- 全通畅流道, 流通能力大
- 可选用PTFE填料或柔性石墨填料
- 可选用锥形阀芯或钴基合金球形阀芯
- 可应用于面板安装
- 阀体底部可选设安装螺孔
- 阀体型式有直通和角式可供选择
- 连接型式多样
- 100%工厂试验
- The design of combined bonnet structure can ensure the reliable sealing performance during the strict working environment.
- Safety back seating seals in full open position
- The flow ability is large due to the full NG channel.
- PTEE packing or soft graphite are available.
- Tapered stem tip or cobalt-base alloy ball stem tip are available.
- Panel mounting available
- Optional mounting holes at the bottom of the body
- Body type:straight pattern and angle pattern
- Various connection
- 100% factory tested

技术规范

- 最高工作压力:
不锈钢、合金600: 6000 psig (414 bar)
合金400: 5000 psig (344 bar)
- 公称通径: 6mm, 10mm
- 许用温度范围:
PTFE填料: -54~232℃
柔性石墨填料: -54~648℃
- 接口型式和尺寸:
接口型式多种多样, 可根据用户需要灵活配置。常用接口如下:
 - 双卡套连接DF:
米制管 $\phi 10\sim 22$ mm;
英制管 3/8"~3/4"
 - 活接对焊UBW: $\phi 12\sim 18$ mm
 - NPT外螺纹(N): 1/4"~3/4"
 - NPT内螺纹(FN): 1/4"~3/4"

Specification

- Maximum working pressures:
Stainless steel and Alloy 600: 6000 psig (414 bar)
Alloy 400: 5000 psig (344 bar)
- DN: 6, 10 mm
- Applicable temperature range:
PTFE packing: -54~232℃
Soft graphite packing: -54~648℃
- Interface type and size
The interfaces are various and can be decided by customer's requirement. The common interfaces are as follows.
 - Double ferrules (DF):
Metric tube of 10~22 mm;
Fractional tube of 3/8"~3/4"
 - Union butt welding (UBW): 12~18 mm
 - NPT male thread (N): 1/4"~3/4"
 - NPT female thread (FN): 1/4"~3/4"

NU系列组合阀盖式针形阀

NU Series Union Bonnet Needle Valves

江花®
JIANGHUA

- BSPT外螺纹(R): 1/4"~3/4"
- BSPT内螺纹(Rc): 1/4"~3/4"
- T管承插焊(TSW): 12-28 mm
- P管承插焊(PSW): 1/4"~3/4"
- BSPT male thread 1/4"~ 3/4"
- BSPT female (Rc) : 1/4"~3/4"
- Tube socket welding (TSW): 12~28 mm
- Pipe socket welding (PSW): 1/4"~3/4"

压力温度等级 Pressure-Temperature Ratings

ASME等级 ASME Class	2500		
材料组别 Material Group	2.2	3.4	3.5
材料名称 Material Name	316 SS	合金400 Alloy 400	合金600 Alloy 600
温度 Temperature, °C (°F)	工作压力 Working Pressure, psig (bar)		
-53 to 38 (-65 to 100)	6000 (413)	5000 (344)	6000 (413)
93 (200)	5160 (355)	4400 (303)	5600 (385)
121 (250)	4910 (338)	4260 (293)	5460 (376)
148 (300)	4660 (321)	4120 (283)	5320 (366)
176 (350)	4470 (307)	4050 (279)	5220 (359)
204 (400)	4280 (294)	3980 (274)	5120 (352)
232 (450)	4130 (284)	3970 (273)	5030 (346)
260 (500)	3980 (274)	—	4940 (340)
315 (600)	3760 (259)	—	4780 (329)
343 (650)	3680 (254)	—	4700 (323)
371 (700)	3620 (249)	—	4640 (319)
398 (750)	3560 (245)	—	4430 (305)
426 (800)	3520 (242)	—	4230 (291)
454 (850)	3480 (239)	—	4060 (279)
482 (900)	3460 (238)	—	3745 (258)
510 (950)	3220 (222)	—	2725 (187)
537 (1000)	3030 (208)	—	1800 (124)
565 (1050)	3000 (206)	—	1155 (79.5)
593 (1100)	2545 (175)	—	770 (53.0)
621 (1150)	1970 (135)	—	565 (38.9)
648 (1200)	1545 (106)	—	515 (35.4)

注: 额定值是以选配石墨填料的针形阀为准. 标准PTFE填料温度额定值:232°C

Note: Ratings are based on needle valves with optional graphite packing. Temperature rating for standard PTFE packing: 232°C

结构材料 Materials of Construction

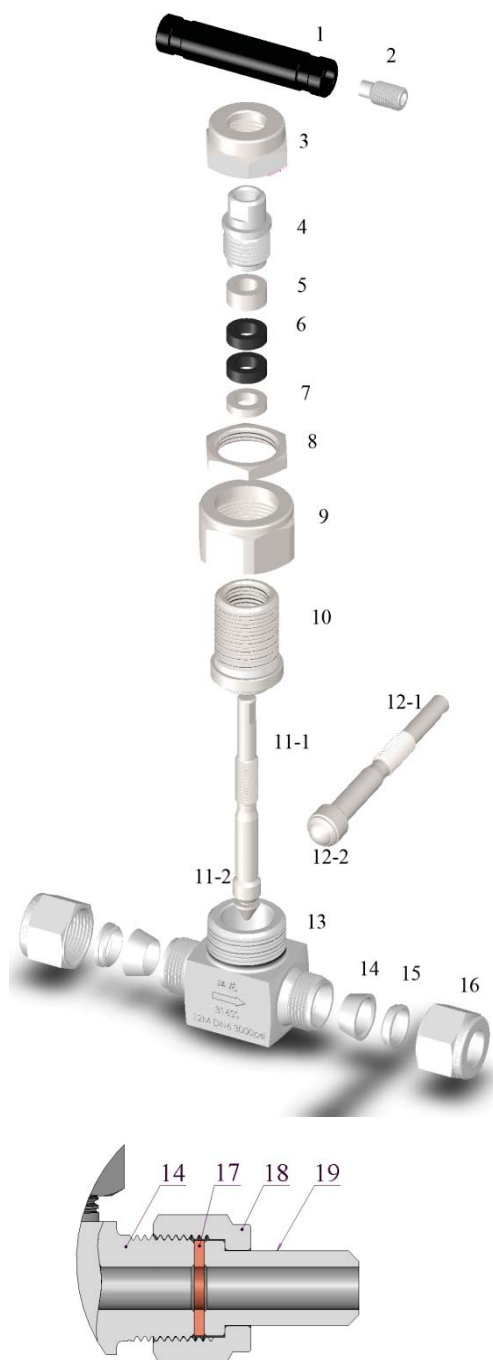

活接对焊型式 Union butt welding type

序号 No.	部件 Components	阀体材料 Material			
		304SS	316SS	合金 Alloy 400	合金 Alloy 600
1	手柄 Handle	阳极化铝, 304SS Anodized aluminum, 304SS			
2	紧定螺钉 Set screw	不锈钢或镀镍镉钢 Stainless steel or Nickel cadmium-plated steel			
3	锁紧螺母 Lock nut	304SS	316SS		
4	填料螺栓 Packing bolt	416SS			
5	接套 Gland	304SS	316SS	合金 Alloy R-405	合金 Alloy 600
6	填料 Packing	聚四氟乙烯, 石墨 PTFE or graphite			
7	填料垫 Packing washer	304SS	316SS	合金 Alloy R-405	合金 Alloy 600
8	薄螺母 Thin nut	304SS	316SS		
9	阀盖螺母 Bonnet nut	304SS	316SS		
10	阀盖 Bonnet	304SS	316SS	合金 Alloy R-405	合金 Alloy 600
11-1	锥芯阀杆 Tapered tip	304SS	316SS	合金 Alloy R-405	合金 Alloy 600
11-2	锥形阀芯 Tapered tip	316SS 氮化或焊 Stellite 316SS Nitriding or welding Stellite			
12-1	球芯阀杆 Ball tip Stem	304SS	316SS	—	—
12-2	球形阀芯 Ball tip	司太立合金 Stellite		—	—
13	阀体 Body	304SS	316SS	合金 Alloy 400	合金 Alloy 600
14	前卡套 Front ferrule	304SS	316SS	合金 Alloy R-405	合金 Alloy 600
15	后卡套 Back ferrule	304SS	316SS	合金 Alloy R-405	合金 Alloy 600
16	卡套螺母 Ferrule nut	304SS	316SS	合金 Alloy R-405	合金 Alloy 600
17	垫片 Washer	聚四氟乙烯, 铜, 铝 PTFE, copper or aluminum			
18	外套螺母 Jacket nut	304SS	316SS		
19	焊接接管 Welding nipple	304SS	316SS	合金 Alloy R-405	合金 Alloy 600

注：表中结构材料为我公司典型配置，根据介质及 温度状况可能有变动，也可按顾客要求制造。

Note: The material in the sheet is used on manufacturing the common product in our company. We can manufacture manufacture as the customer's requirements according to the change of the medium and temperature condition.

NU系列组合阀盖式针形阀

NU Series Union Bonnet Needle

江花®
JIANGHUA

尺寸 Dimensions

尺寸仅供参考, 可能变动。

Dimensions are for reference only and are subject to change.

直通阀

Straight pattern

NU6-G-TSW14-S6

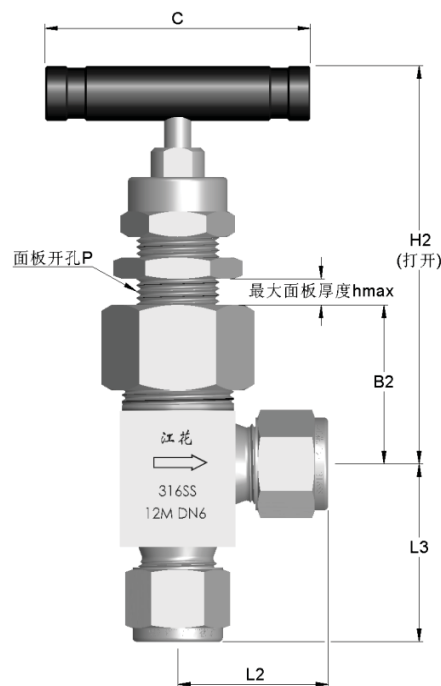
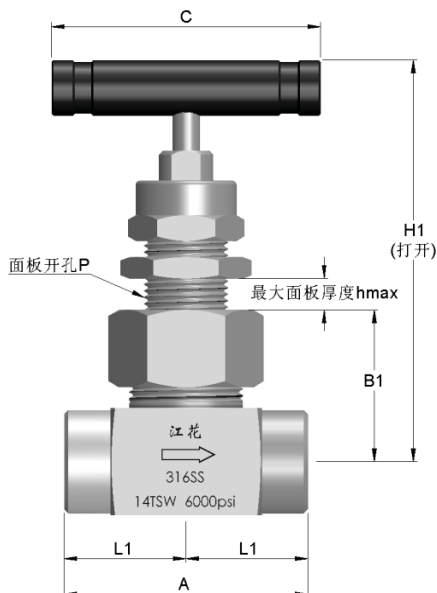

角式阀 Angle pattern NU6A-DF12M-S1

规格尺寸表 Table of model and dimensions

基本型号 Basic type	连接型式/尺寸 Connection Type and Size		尺寸 size mm										
	进口 Inlet	出口 Outlet	A	L1	L2	L3	B1	B2	C	hmax	H1	H2	P
NU6系列 (6.0mm) NU6 series													
NU6-DF10M	双卡套公制管10mm Double ferrules for metric tube	同进口 Same as inlet	75.0	37.5	34.5	40.0	35.3					97.5	
NU6-DF12M	双卡套公制管12mm Double ferrules for metric tube		78.6	39.3	36.3	41.8	35.3					98.5	
NU6-DF14M	双卡套公制管14mm Double ferrules for metric tube		75.0	37.5	34.5	40.0	35.3	35.3	64.0	9.5		97.5	22.5
NU6-DF3/8	双卡套英制管3/8" Double ferrules for fractional tube		78.6	39.3	36.3	41.8	35.3					98.0	
NU6-DF1/2	双卡套英制管1/2" Double ferrules for fractional tube		128.0	64.0	61.0	64.5	35.3						
NU6-UBW14	活接对焊14mm Union butt weld		58.0	29.0	26.0	26.0							
NU6-FN1/4	1/4"NPT内螺纹 Female NPT												
NU6-FN3/8	3/8"NPT内螺纹 Female NPT												

规格尺寸表 Table of model and dimensions

基本型号 Basic type	连接型式/尺寸 Connection Type and Size		尺寸 size (mm)														
	进口 Inlet	出口 Outlet	A	L1	L2	L3	B1	B2	C	hmax	H1	H2	P				
NU6系列 (6.0mm) NU6 series																	
NU6-TSW14	T管承插焊14mm Tube socket weld	同进口 Same as inlet	58	29	26	26	35.3	35.3	64	9.5	98	97.5	22.5				
NU6-PSW1/4	P管承插焊1/4" Pipe socket weld																
NU10系列 (10.0mm) NU 10 series																	
NU10-DF12M	双卡套公制管12mm Double ferrules for metric tube	同进口 Same as inlet	90.6	45.3	42.8	42.8	45.2	45.2	88.0	11.0	118	118	27.5				
NU10-DF14M	双卡套公制管14mm Double ferrules for metric tube				44.3	44.3											
NU10-DF1/2	双卡套英制管1/2" Double ferrules for fractional tube				42.8	42.8											
NU10-DF3/4	双卡套英制管3/4" Double ferrules for fractional tube				46.9	46.9											
NU10-UBW18	活接对焊18mm Union butt weld				45.2	45.2											
NU10-FN1/2	1/2"NPT内螺纹 Female NPT				34.5	34.5											
NU10-FN3/4	3/4"NPT内螺纹 Female NPT				47.8	—											
NU10-N1/2-FN1/2	1/2"NPT外螺纹 Male NPT	1/2"NPT 内螺纹 Female	80.0	40.0	34.5	34.5	88.0	45.2	45.2	11.0	118	118	27.5				
NU10-TSW14	T管承插焊14mm Tube socket weld	同进口 Same as inlet	78.0	39.0	33.5	38.0											
NU10-TSW16	T管承插焊16 mm Tube socket weld													47.8	—		
NU10-TSW18	T管承插焊18mm Tube socket weld																
NU10-TSW22	T管承插焊22mm Tube socket weld																
NU10-TSW28	T管承插焊28 mm Tube socket weld															121	—
NU10-PSW1/2	P管承插焊1/2" Pipe socket weld															118	118
NU10-PSW3/4	P管承插焊3/4" Pipe socket weld						121	—									

NU系列组合阀盖式针形阀

NU Series Union Bonnet Needle Valves



订购须知 Ordering information

阀门系列 Series	阀体型式 Body type	阀芯型式 Type of stem tip	密封面材料 Seat Material	填料材质 Packing material	进口型式 Inlet Type	进口尺寸 Inlet Size	出口型式 Outlet type	出口尺寸 Outlet Size	阀体材料 Body Material
NU6	直通阀 Straight pattern	锥形阀瓣 Tapered stem tip	与阀体同 Same as body	聚四氟乙烯 PTFE	N NPT外螺纹 Male NPT	1/4, 3/8, 1/2, 3/4,	与进口相同 Same as inlet	与进口相同 Same as inlet	S1 321SS
	角式阀 A Angle pattern	司太立球形阀瓣 B Stellite ball stem tip	Y Stellite	G Graphite	FN NPT内螺纹	1/4, 3/8, 1/2, 3/4,			S4 304SS
NU10					R BSPT外螺纹 Male BSPT	1/4, 3/8, 1/2, 3/4,	标识方法同进口型式和 尺寸 Specify in the same way as inlet Type and inlet size		S6 316SS
					Rc BSPT内螺纹 Female BSPT	1/4, 3/8, 1/2, 3/4,			F11 12Cr1MoV
					DF 双卡套公制管 Double ferrule for metric tube	10M, 12M, 14M, 18M, 22M			M 合金 400 Alloy 400
					DF 双卡套英制管 Double ferrule for fractional tube	3/8", 1/2", 3/4"			INC 合金 600 Alloy 600
					UBW 活接对焊 Union butt weld	12, 14, 16, 18			
					TSW T管承插焊 Tube socket weld	14, 16, 18, 22, 28			
					PSW P管承插焊 Pipe socket weld	3/8", 1/2", 3/4"			

手柄 Handle
黑色氧化铝棒 Black Aluminum bar
1 蓝色氧化铝棒 Blue Aluminum bar
2 304不锈钢棒 304SS bar

镇江市华阳机电制造有限公司

电话:0511-88431885 传真:0511-88431333

E-mail:huayang@vip.163.com

常见接口型式图例 Common interface type

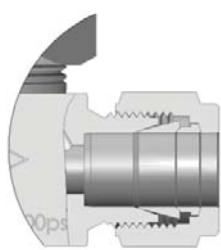

双卡套 Double ferrules

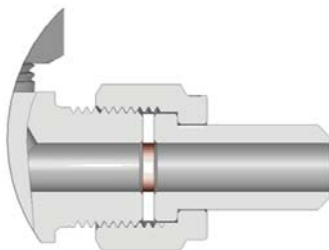

活接对焊 Union butt weld



内螺纹 Female

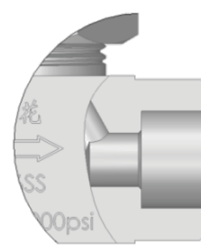

承插焊 Socket weld

其它订购信息

- 直通阀为标准型式，不需要订购代码，如需角式阀，应加代码“A”
- NU系列阀使用316SS材料制成并经热处理的锥形阀芯为标准配置，如需钴基合金球形阀芯，应加代码“B”
- 阀座密封面如需堆焊Stellite合金，应加订购代码“Y”
- NU系列阀使用PTFE填料为标准配置，如需柔性石墨填料，应加代码“G”

Other purchase information

- The straight valve is the standard type which don't need any purchase code.If you need the angle pattern, pls add code "A".
- NU series valve is made of 316SS. The tapered core without any heat treatment is the standard configuration. If you need cobalt-base alloy ball core, pls add code "B".
- If the sealed face of the valve base need bead welding the Stellite alloy, pls add the purchase code "Y".
- NU series valve used PTFE packing as the standard configuration. If you need soft graphite packing, pls add code "G".

型号举例说明：

NU10A-G-TSW16-TSW14-S1

NU10A: NU10系列针形阀，角式阀，锥形阀芯
密封面材料同阀体

G: 石墨填料

TSW16: 进口型式为Tube管承插焊接，尺寸 16mm

TSW14: 出口型式为Tube管承插焊接，尺寸 14mm

S1: 阀体材料为321SS

For example

NU10A: NU10 series needle valve, angle pattern.

tapered stem tip, the seat material is same as body

G: graphite packing

TSW16: inlet type is Tube socket weld with size of 16mm

TSW14: outlet type is Tube socket weld with size of 14mm

S1: Material of valve body is 321SS